

Application Notes
©Infrared, Inc.

**CONTAMINATION MONITORING OF RSRM BONDING SURFACES
USING OPTICALLY SIMULATED ELECTRON EMISSION (OSEE)**

BACKGROUND

During the development of the Redesigned Solid Rocket Motor (RSRM), NASA required Morton Thiokol, Inc. to implement contamination control and cleanliness verification of critical bonding surfaces. An inspection method which would be quantitative and provide a written record showing the actual level of contamination on bonding surfaces versus a reject level was required. The Materials and Processes Laboratory of Marshall Space Flight Center [MSFC] developed a quantitative technique for bonding surface cleanliness inspection. This technique was sensitive enough to detect contamination levels that were overlooked by existing methods such as black light and visual inspection. Not only was the threshold of detection lower with this technique, but it also offered a quantitative estimate of the contamination level, and was capable of producing a written record. This technique can also be used as a research tool to investigate levels of contamination at which bonding would be significantly degraded for a given substrate and adhesive system. Reject levels could be established for a given bonding system using these data.

An important advantage of the technique developed at MSFC was the real time analysis ability. Other methods capable of monitoring contamination levels of an equivalency low range, such as spectrochemical analysis and Non Volatile Residue (NVR) sampling, require lengthy laboratory turnaround times. These analytical techniques involve difficult sample collection methods that are impractical to utilize over more than a fractional area of large hardware components such as the RSRM casing segments. The method of monitoring large scale bonding surfaces for contamination at Morton Thiokol has previously been the black light inspection. The limitations of the black light technique are many. First the black light is only useful for the detection of contaminants that strongly fluoresce in the ultraviolet around the 365 nm spectral line, such as the Conoco HD-2 (corrosion inhibitive) grease used at Morton Thiokol. Light machine, tapping oils and hydraulic oil. Most silicone RTV's do not fluoresce strongly at low levels of contamination that are of concern for bonding integrity. Secondly, the threshold of detection for HD-2 grease with the black light in practicable lighting conditions (5 foot candles or less) and with an experienced operator is 100 mg/sq ft which exceeds the maximum allowable contamination. Moreover, black light inspection is subjective, not quantitative and creates no inspection record for archives and future reference or analysis.

OSEE - TECHNIQUE DESCRIPTION

The OSEE inspection method utilizes Photoelectron Emission (PEE) and was developed to monitor cleanliness of the space shuttle external tank. This method was investigated for MSFC by Tennyson Smith of Rockwell International and Robert Bowen of Scientific Services. Photo Emission Tech., Inc. [PET] has developed an instrument to measure surface contamination levels in industry. PET remains the sole manufacturer of the OSEE instrument and Infrared, Inc. of Reno NV. is an authorized supplier.

This technology has previously been utilized as a relative contamination detection tool in clean room environments including semiconductor and floppy disk manufacturing. Dr. Raymond Gause was able to correlate OSEE readings to contamination levels of Conoco HD-2 grease at MSFC Materials and Processes Laboratory using the

PET instrument. Conoco HD-2 grease is an important substance monitored on the RSRM hardware. It is used as a corrosion inhibitor on steel RSRM case cylinders during storage, and for joint protection after the cylinders are assembled. A residual layer of this grease remaining on bonding surfaces after vapor degreasing or hand cleaning could cause bond degradation.

A prototype scanning system was assembled at Morton Thiokol, in July of 1987. A second iteration system was installed in November of 1987 that increased the reliability of the sensor position control. Software improvements were also made at that time to make the system more user friendly. Morton Thiokol has continued to make minor improvements on the equipment and software but the system has been used in its basic original design since November 1987.

OSEE is based on the photoelectric effect where electromagnetic radiation of the proper wavelength is impinged upon a surface which subsequently yields electrons. The surface monitored by OSEE, is irradiated with ultraviolet (UV) light with the major spectral line at 253.7nm. The electrons ejected from the surface are accelerated across a fixed distance or air gap by an accelerating potential on the collector around the mercury vapor lamp. The inspected surface is grounded with reference to the collector and the photoelectrons that flow across the gap creating a photo current loop that is detected by the control unit. The control unit basically is a Pico ammeter and a power supply for the sensor bulb and the sensor electronics. A contaminant on the surface will attenuate the photocurrent and produce a lower reading on the control unit. Levels of contamination as low as one (1) mg/sq ft are detectable with OSEE.

The attenuation of the photocurrent resulting from a contaminant on the surface is the result of two major factors. First, the photoemitting surface is not irradiated as strongly because of the contaminant covering the surface, i.e. fewer photons reach the surface and fewer electrons are emitted. Second, many of the electrons that are emitted cannot get through the contaminant because it acts as a "resistance". The electrons simply get bogged down in the contaminant. The thicker a layer of contamination on a surface the lower the resulting photo current detected. Oxides, with the exception of nickel-oxide, also attenuate the photo current. Oxides are non-photo emitting at this wavelength and electrons on the metal surface cannot escape from the oxide surface.

OSEE EQUIPMENT DESCRIPTION

The OSEE Surface Quality Monitor consists of two components, the sensor and the control unit. Figure 2 shows a block diagram of the interconnection of these components.

Regulated line voltage supplied to the control unit powers the step-up transformer power supply (for the mercury vapor bulb in the sensor) and the low voltage DC power supplies (for the control unit electronics and sensor gain amplifiers). The mercury vapor bulb requires 800 volts AC momentarily upon start up. After the bulb fires this voltage drops down to approximately 270 volts as the current through the bulb increases.

On the end of the sensor, between the UV bulb and the surface to be inspected, an anode or collector (with a potential of +45 volts) attracts electrons photoelectrically generated from the surface, forming a small current. This signal is amplified in the sensor head enough that it can be transmitted over a 60 foot sensor cable. In the control unit, the signal is filtered to exclude noise from the bulb and other AC sources. This ground must be connected to the surface to be tested.

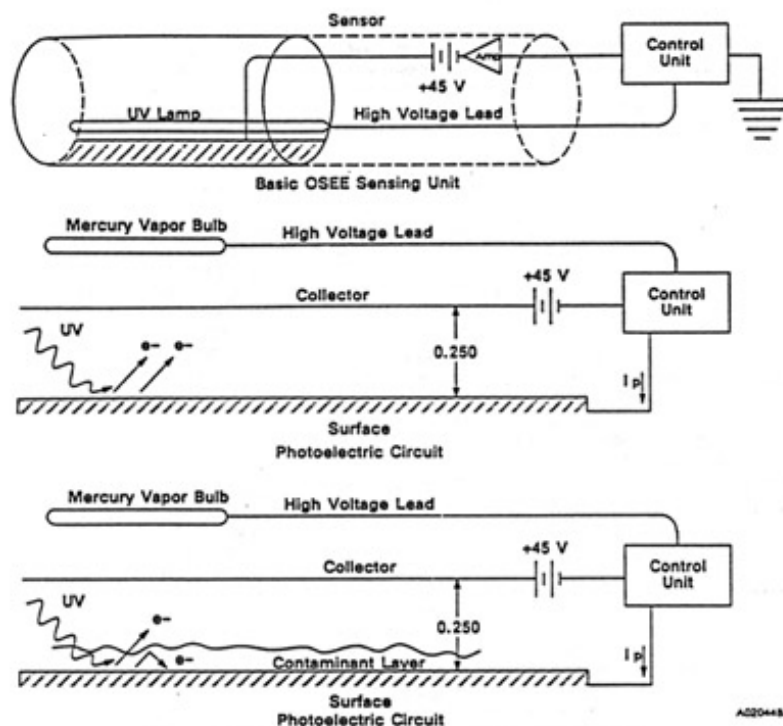

Figure 1. The Effect of Contamination on Photoelectric Emission

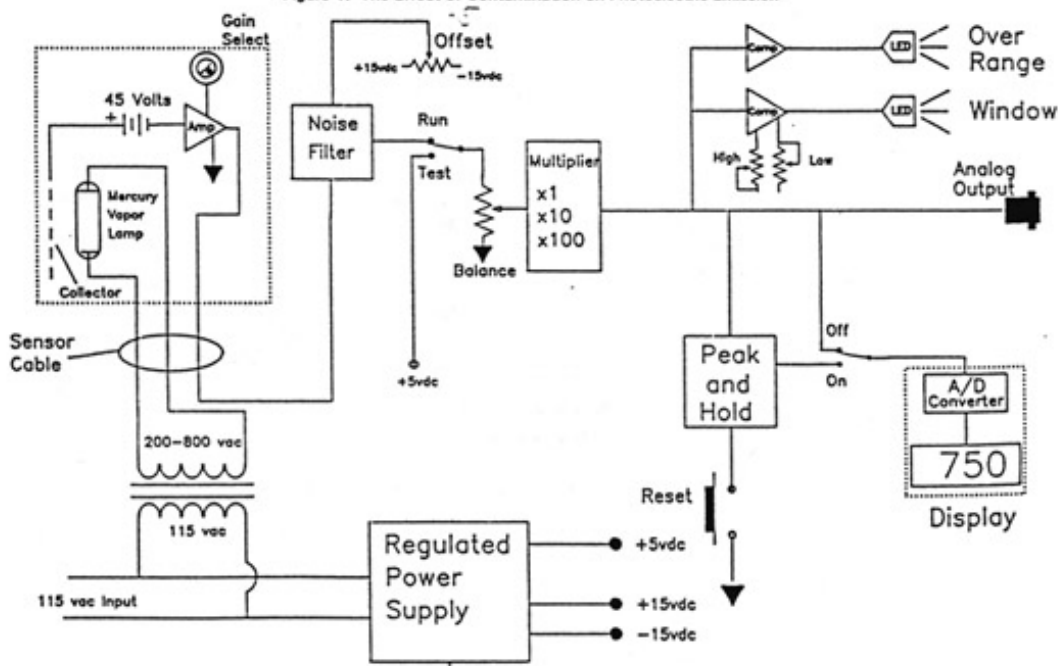

Figure 2. OSEE Monitor Block Diagram



The signal is picked up on a variable resistor balance control that is used for calibration setting, and processed through a multiplier chip that amplifies the signal again if the gain on the sensor is not sufficient. Position "1" is unity gain, position "10" is ten fold-gain, and position "100" is 100 fold-gain amplification. Finally the signal reaches the digital panel meter (DPM) circuit. The DPM converts the signal from analog to digital and displays it on the seven-segment display of the DPM.

There are a few options or alternatives to the signal processing flow. One alternate circuit is activated when the peak-detect function is selected. When the peak-detect switch is in the on position, the signal is routed through a circuit that locks in on the highest signal measured until the reset button is pressed. Pressing the reset button re-zeros the circuit. The peak signal is then converted to digital in the A/D converter and displayed on the DPM.

The signal is also automatically processed through an accept/reject indicator circuit whenever the control unit is powered on. This circuit provides the capability of setting a "window" of acceptable readings. A green LED on the sensor lights up when the signal from the inspected surface is below the high window limit and above the low window limit, indicating that the surface is within preset acceptable limits. If the signal is outside this acceptable window, a red LED lights up indicating rejection.

An over-range indicator LED lights up on the control unit if the sensor gain is set too high for the signal received at the sensor, indicating amplifier saturation. A sample ground indicator LED on the control unit flashes if the surface to be inspected is not properly connected to the sample ground on the rear panel of the control unit. This ground must be connected to the surface in order to provide a return path for the current.

An analog output connector, to further process or record signals on external equipment such as a computer or chart recorder, is provided. Analog signals may be monitored on external equipment simultaneously with the DPM reading on the control unit provided the external monitoring equipment is of sufficiently high impedance.

OSEE AUTOMATED SYSTEM

Prior to chemlok adhesive application to the RSRM casing segments, the OSEE surface quality monitoring technique is utilized to ensure high levels of cleanliness of the bonding surfaces. These surfaces are large, being over 1,000 square feet in area. Figure 3 is a block diagram of the equipment interface used to perform that inspection. Central to the technique is the OSEE control unit and sensor. It evaluates the surface quality in all surface cleanliness measurements. Several pieces of equipment are interfaced with the OSEE monitor during the automated scans that position the OSEE sensor and record and display data.

A fixed standoff distance is critical to OSEE measurements to maintain the sensor-to-surface gap. Casing segments have either a run out or a wobble or both on the turntable. If the sensor was fixed in the center of the segment and the case rotated around it, the gap may increase or decrease to as much as three inches as the case runs out. One major component of the automated scan system is the robotic proximity servo that positions the sensor as the surface rotates. This robotic servo maintains the 0.250" (± 0.005 ") gap between the sensor and the surface. The sensor is mounted on a slide bearing that can move radially inward and outward. An eddy current proximity detector mounted on the OSEE sensor monitors the distance to the case surface. An electronic signal, from the proximity detector dependant upon whether the sensor is closer or farther than 0.250 inches, is sent to one servo control box. The control box sends power to the servomotor, enabling it to move the sensor away from or toward the case respectively. In this manner the sensor gap remains within the acceptable range.

www.infrared.com

5301 Longley Ln Suite D-154 Reno, NV 89511 - 775-827-2440 - FAX: 775-827-2441

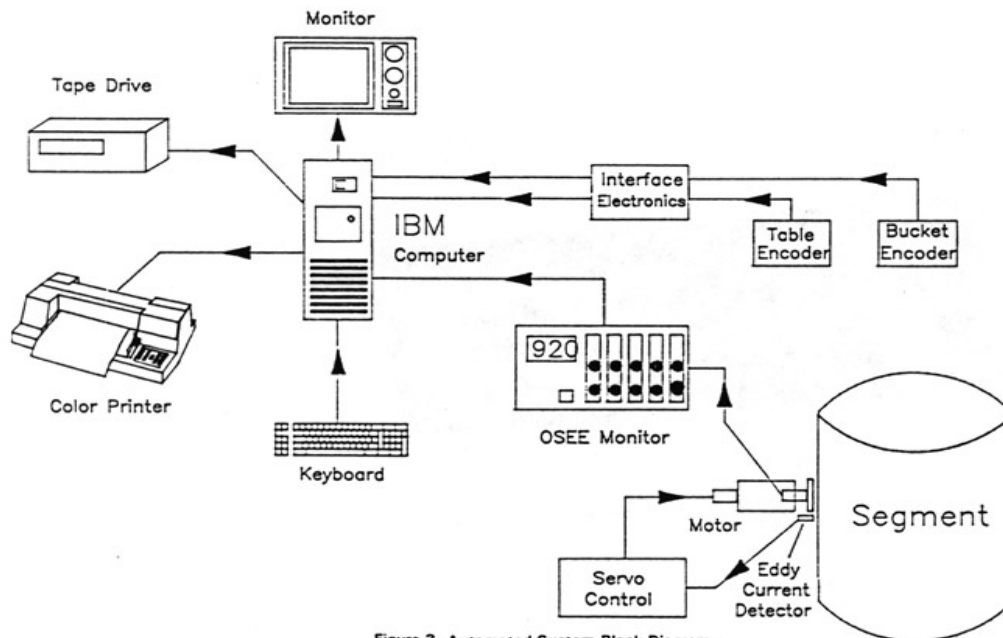

Figure 3. Automated System Block Diagram

The other major component of the automated OSEE scan system is an IBM computer. It is interfaced with the OSEE control unit to record and display the data. The computer receives the OSEE signal via the analog output of the OSEE control unit. A coax cable connects this output to an A/D board in the computer. The scanning program software periodically reads the A/D board and stores the data. Also interfaced with the computer are the turntable encoder, the zero position interrupt and the height encoder. These encoders enable the computer to determine the sensor position at the same time it reads the A/D board. With these simultaneous inputs the computer can create a real time color-coded map of contamination levels and display it on the monitor. Angular and vertical location are determined by the coordinate scaling of the horizontal and vertical axes of the map, see Fig. 4.

The computer keyboard gives the operator control of the computer and enables him to select programs, input data and end a scan session. The computer monitor provides real-time scan monitoring and computer operation feed back. A scan map may be printed on the color printer directly from the monitor to produce a hard copy. For permanent records, the scan files may be backed up off the computer hard disk onto high-density floppy disks (1.2 megabytes) or onto a removable hard disk (15 megabytes). Using these media, the data can be statistically analyzed and archived.

Case bonding surfaces can be monitored with OSEE using scanning rates as high as (2) RPM or approximately 74 feet per minute. At this rate the actual scanning time for a segment of over 1,000 square feet is approximately one half hour when using a six inch sensor.

MANUAL SCAN WITH COMPUTER DATA ACQUISITION

Many surfaces must be scanned manually, that is, without robotic sensor positioning or automated surface movement. These surfaces have been OSEE inspected at Morton Thiokol using a fixed standoff tool on a one (1) inch

OSEE sensor with the peak detect function on the OSEE control unit. In this mode a spot check may be made of the hardware to obtain a surface quality evaluation after processes that are homogeneous in nature, such as vapor degreasing. This technique requires two inspectors: one to position the sensor over the correct location on the surface being monitored and another to reset the peak detect circuit and record the readings. The problem with this technique is that the two inspectors must coordinate their work precisely so the reading is taken just after the sensor has stabilized on the surface. Inadvertent movement of the sensor during measurement may cause an erroneously high reading. The recording of the reading from the DPM may lead to errors, especially during a long session of inspection as numbers can easily be recorded inaccurately. To address these concerns, a computer system has been implemented to eliminate the peak detect function and record data automatically, making manual inspection a one-man operation. See Fig. 5 and 6.

Computer software has been developed to read the OSEE signal from the analog output of the control unit. After a button has been pressed on the sensor the computer makes 5000 measurements in one second. It then takes an average of these measurements and records it as the value at the particular location inspected. After all locations have been monitored, a printout of the data is made available. On the manual system the data is also contained on the hard disk of the computer and can be backed onto floppy disks. This new technique of measurement has improved the quality of the data and has sped up manual scans of hardware.

CALIBRATION OF THE OSEE SYSTEM

Dr. Gause at MSFC correlated different amounts of HD-2 grease on D6AC steel (measured in milligrams per square foot) to OSEE signal level. Figure 7 is a plot of OSEE signal versus contamination with HD-2 grease on D6AC steel. There is a nonlinear relationship between contamination and OSEE readings developed by Dr. Gause for HD-2 grease:

$$R=10^{-0.145 \log C + 2.78}$$

Where R is the OSEE reading on the control unit and C is the contamination level.

The relationship will have to be developed empirically for each contaminant (and substrate) of interest if precise quantification of other contaminants is required.



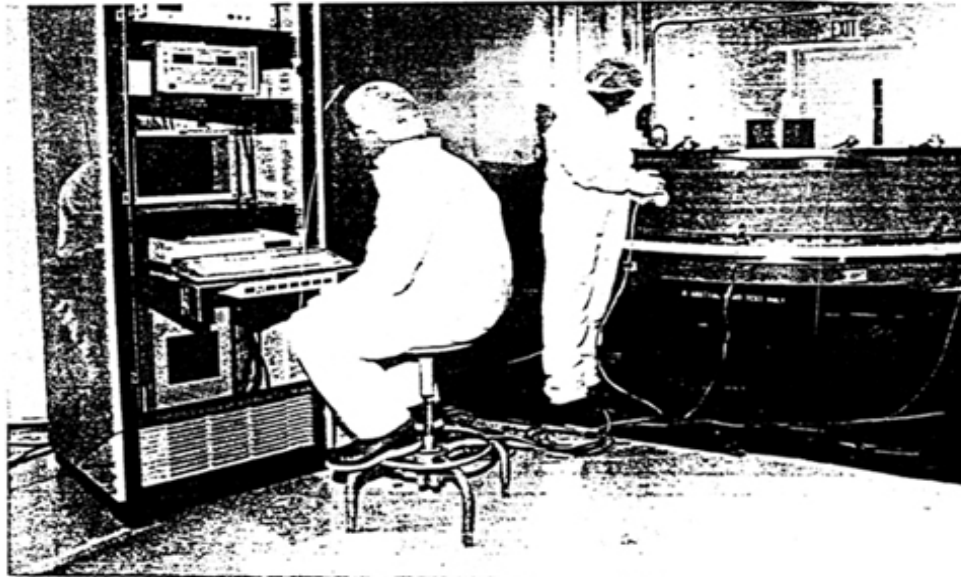
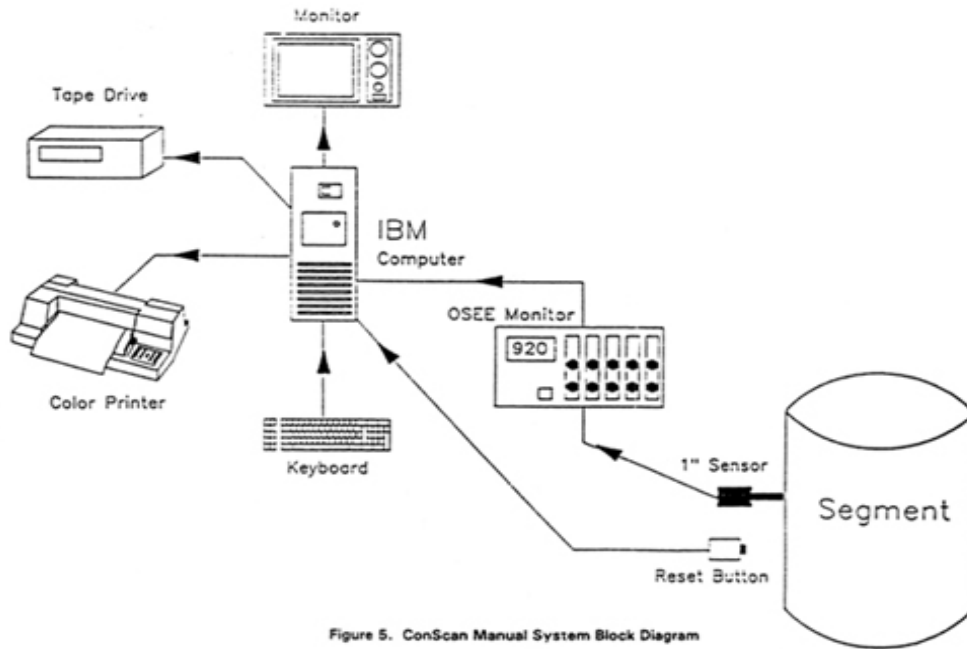

Figure 6. Computerized Manual Inspection

To obtain repeatable, reliable data it is necessary that the OSEE instrument is electronically at the same set point before each use. A chromium calibration standard was developed to adjust Dr. Gause's OSEE instrument. While baseline data was accumulated on HD-2 grease, the laboratory instrument read 920 centivolts on the chromium standard. In order to quantify contamination levels seen on hardware at Morton Thiokol, it is important to know that the instrument is set electronically just as the one at MSFC. Contamination levels can then be equated to levels of HD-2 grease. A stainless steel calibration standard has been developed for on-line use at Morton Thiokol, since the chromium standard (chrome vapor deposited on glass), was not rugged enough for the industrial environment. When the stainless steel calibration standard is thoroughly clean it reads 825 centivolts. The same instrument responds to a chromium standard at 920 centivolts. Therefore when the OSEE instrument reads 825 on a properly cleaned stainless standard, measurements should correlate to Dr. Gause's for HD-2 grease on D-6AC steel. A problem arises in the



statement “properly cleaned”. The evidence that OSEE has shown is that cleaning a surface is no trivial matter. To measure the same quality surface on a standard each time the instrument is used in the manufacturing area is nearly impossible. Recent studies have shown that the trends of data on freshly grit blasted steel plates lead to more consistent data than the calibration standard data. This study would indicate that calibration at the time of scanning only confuses the data.

One calibration technique presently under investigation is the use of UV light intensity and electronic gain. A research grade UV radiometer has been acquired and studies have been conducted to determine the possibility of its use in calibration. There is a direct correlation between UV intensity and the OSEE signal, and it is known that bulb intensity deteriorates with time. Therefore, compensation could be made for bulb deterioration if the power supply to the bulb were made adjustable. To adjust the OSEE electronics, a carefully plotted and shielded 50gigaohm resistor may be connected between the collector and the ground. The balance potentiometer may then be adjusted to a set value. In time, this may become a routine calibration made periodically and the calibration plate on-line may be discarded.

Another approach to the calibration question, under investigation is the development of two or three calibration standards made of oxidation resistant metals. These metals, such as gold, nickel and chromium, have different signal outputs on OSEE (i.e. different work functions). Since the OSEE response is nonlinear with contamination it would be best to calibrate to the middle as well as both ends of the response curve. Stainless steel and chromium both give calibration points on the extreme vertically sloped portion of the curve.

OSEE RELIABILITY

Although the PET instrument has reportedly shown few reliability problems in clean room environments, its application in an industrial environment has revealed a few failure modes because of the greater handling. During on-line usage in the industrial manufacturing environment at Morton Thiokol the sensors are subject to a certain amount of shock, particularly during the manual mode of operation, when the sensor is positioned on the steel surface dozens of times on each component. This shock makes the sensor bulb and electronics fail prematurely.

The 60 foot long cables are subjected to greater flexing on-line than they would experience in a clean room manufacturing environment, where they typically are installed in a fixed position on a product line and are seldom moved. The single greatest failure mode of the sensors has been the high voltage conductor in the cable. This failure mode was addressed with PET and subsequent sensors received were fitted with a heavier gauge high voltage conductor and potted connectors with improved strain relief. These changes not only improved the equipment reliability, but also prevented high voltage from arcing over to other connector leads, eliminating more extensive electronic damage.

VARIABLES AFFECTING DATA

There are several variables that affect data reliability. Care must be exercised in surface monitoring to minimize erroneous data. The OSEE signal is inversely proportional to the square of the distance from the UV source to the surface. The electric field of the accelerating potential is inversely proportional to the distance between the collector and the surface. The drop off of intensity is the dominant variable because the number of photons available for photoelectric interaction drops off inversely with the square of the distance. Because of this sensitivity, the standoff

www.infrared.com

5301 Longley Ln Suite D-154 Reno, NV 89511 - 775-827-2440 - FAX: 775-827-2441

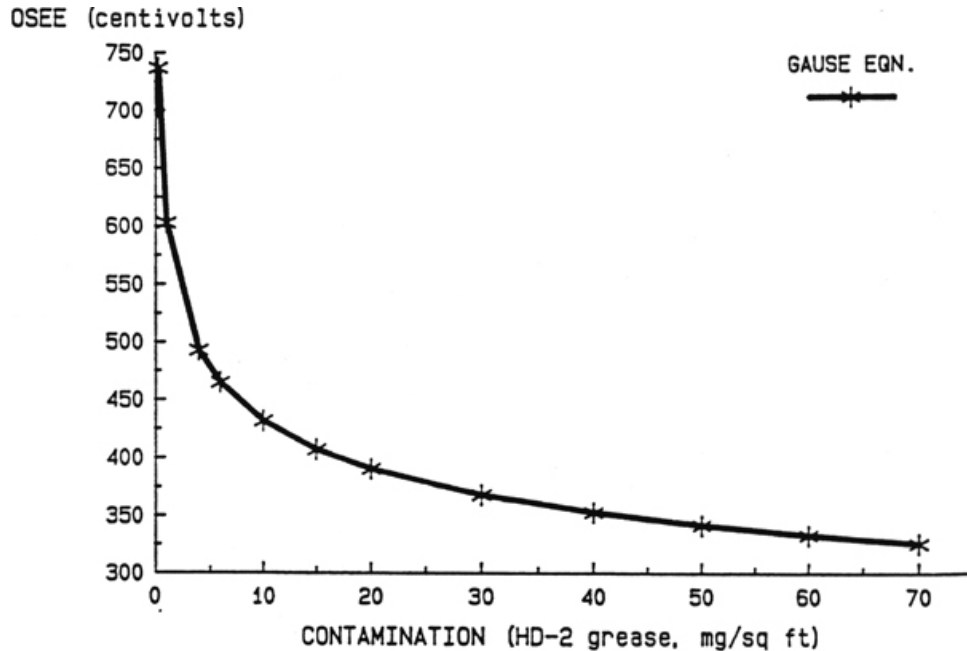

distance should be maintained within ± 1 percent of the normal standoff distance. Figure 8 shows a plot of OSEE signal versus standoff distance. AC-line voltage affects the OSEE signal because the mercury vapor bulb power supply is not regulated. Figure 9 shows the relationship between the OSEE signal normalized at 115 volts AC and the line AC voltage. Morton Thiokol has acquired line voltage regulators that regulate to ± 0.1 percent and can be adjusted between 110 and 120 volts. Without this regulation, line voltage drops can seriously affect data.

There are a few Contaminating substances that increase the photoelectron emission, possibly causing a greater OSEE signal than the substrate alone. Therefore, this type of substance could make a surface appear clean that was not. Generally these substances are metals with work functions that are lower than, or equal to, that of the substrate. Conoco HD-2 grease is actually composed of light hydrocarbon oil and calcium compounds that inhibit corrosion. Because of these calcium components, HD-2 grease yields a greater OSEE signal than would a similar coating of another grease that is pure hydrocarbon and does not photo emit. This is a variable to keep in mind when using OSEE but so far all of the contamination of interest at Morton Thiokol have been non-photo emitters or low emitters like HD-2 grease.

SURFACES AND SUBSTRATES

The first surfaces to be monitored with OSEE at Morton Thiokol were on D6AC steel cases. These Surfaces had a surface finish of 70 to 300 Ra and a low, six feet radius of curvature. Abrupt transitions or small radii are not suitable for OSEE evaluation and only low curvature surfaces should be attempted without the use of apertures to decrease the scan width.

OSEE functions best on conductive surfaces so that the electrons photo emitted may be replenished through the ground. Glass cloth phenolic is a poor conductor and although interest has been high at Morton Thiokol in developing the ability to monitor this substrate, reproducible results have been difficult to obtain on glass cloth phenolic. Carbon cloth phenolic is another conductor and shows more promise as a substrate capable of being monitored with OSEE.

Aluminum surfaces are monitored at Morton Thiokol, but there have been problems in quantifying contamination levels on aluminum because the surface chemistry changes quite rapidly (forming oxides) after it is grit blasted. It becomes difficult to differentiate between a clean surface with a heavy oxide and contamination with a small amount of oxide. Investigations continue to attain baseline information on this important substrate. The length of time between grit blast and inspection is a required input into the OSEE system computer allowing it to calculate the expected value clean versus the OSEE value measured.

Recent studies show that D6AC steel yields a dramatically lower OSEE signal after being exposed to air for several days after grit blast. It was believed that this effect was due to oxide formation, but surface chemistry analysis using ESCA has not supported this thesis. While the OSEE technology is quantitative if the contaminant is known, its major weakness is its inability to analyze what is on the surface.

CONCLUSION

The OSEE technique for monitoring contamination is still a developing technology. It has proven very useful at Morton Thiokol as a process aid to cleaning bonding surfaces to a safe and acceptable level. The OSEE inspection technique is an improvement over black light inspection since the range of contaminants detected is of greater breadth and the threshold of detection is lowered to one (1) mg/sq. ft. OSEE provides an objective, documentable method of verifying bonding surface cleanliness.

When interfaced with a computer, OSEE surface evaluations are easily mapped, converting signal levels to contamination levels through predetermined correlation functions derived in the laboratory. The computer interface allows data file creation that greatly simplifies measurement, statistical analysis and archiving. Manual spot monitoring is best accomplished using a computer to record the data because the time required to perform the inspection is shortened and data reliability is improved.

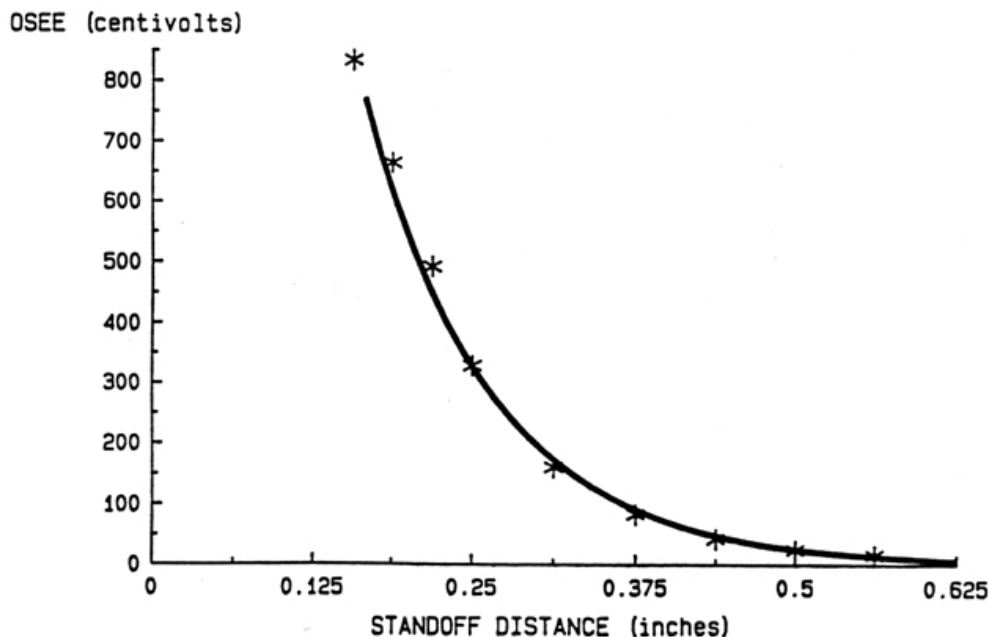

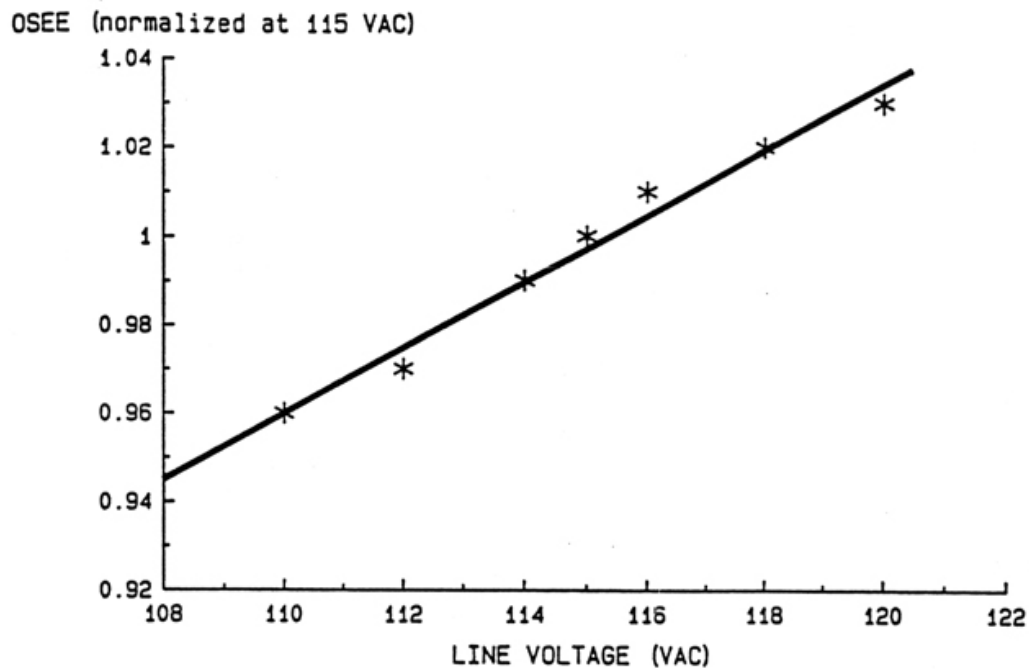

Calibration of the OSEE instrument involves the laboratory baseline data generation as well as instrument calibration to a standard. The particular substrate of interest and the contaminants of concern must be baselined. A calibration reference standard must be developed to keep the on-line instruments operating within the same range as the baseline evaluation instrument in order to improve quantification.

The reliability of the OSEE equipment has been greatly improved with the changes made by PET to the cable design and the cable connectors. Additional improvements for industrial applications are expected in upcoming models. The variable that effects OSEE data the most is the standoff distance. The AC line voltage should be regulated to less than ± 1 percent particularly if the plant line voltage stability is a common problem. There are a number of substances that may be considered contaminants that do photo emit, and may lead to erroneous conclusions about cleanliness levels. All possible sources of contamination should be baselined to evaluate the effect they have toward OSEE measurements on the substrates of interest.

Flat surfaces or surfaces of low curvature are best adapted to OSEE monitoring. Conductive surfaces are more easily inspected with OSEE than nonconductive surfaces. Active metal surfaces, such as aluminum, may require more input (such as the length of time since grit blast) for a particular alloy in order to make an accurate evaluation about surface cleanliness.